

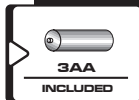

Prolaser® Vector

Model No. 873

User Manual

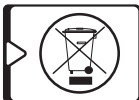
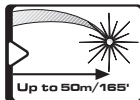
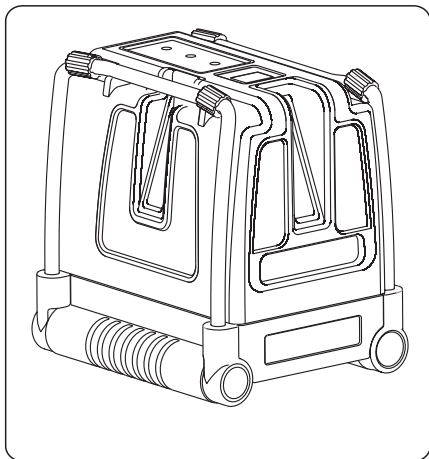

Thank you for purchasing Kapro's 873 Prolaser® Vector.
You now own one of the most advanced laser tools available.
This manual will show you how to get the most out of your laser tool.

APPLICATIONS

The 873 Prolaser® Vector is a laser level with red diodes. The laser is innovatively designed for a very broad range of professional and DIY jobs, including:

- Aligning tiles, marble, cabinets, borders, moldings and trimmings
- Marking lay out for doors, windows, rails, stairs, fences, gates, decks and pergolas installation.
- All types of DIY jobs, including hanging shelves, hanging hooks, pictures, curtains and more

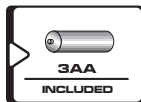
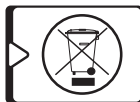
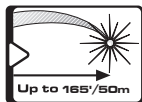

NOTE

Keep this user manual for future reference.

CONTENTS

• Features	4
• Safety instructions	5-6
• Battery installation & Safety	7-8
• Overview	9
• Operating instructions	10-12
• Maintenance	13
• Field calibration test	14-24
• Specifications	25
• Warranty	26



FEATURES

- This Laser tool automatically determines the horizontal and vertical plans
- This laser projects 1 horizontal and 2 orthogonal Vertical red beams, intersects forward and on the ceiling.
- Self-level in automatic mode when the laser is positioned within its self-leveling range.
- Visual and audible “out of leveling range” warning
- Pulse mode emits pulses that can be detected by a detector.
- The max. detectable range of the laser in pulse mode is 50m (165’).
- Manual mode allows angular layout/markings
- Strong and adjustable metal folding legs allow extreme angles mounting and height adjustment
- Locking mechanism to protect the pendulum during transportation.
- 1/4" tripod adaptor
- Shock resistant rubber casing
- Compact size – fits in your toolbox

NOTE

This device contains precision components that are sensitive to external shock, impact or drop that may compromise its functionality – handle with care to maintain its accuracy.

SAFETY INSTRUCTIONS



WARNING

**This product is emitting radiation that is classified
As class II according to EN 60825 -1**

The laser radiation can cause serious eye injury



- Do not stare into the laser beam
- Do not position the laser beam so that it unintentionally blinds you or others.
- Do not operate the laser level near children or let children operate the laser level.
- Do not look into a laser beam using magnifying optical devices such as binoculars or a telescope, as this will increase the level of eye injury.

! WARNING: This product contains lead in solder and certain electrical parts contain chemicals which are known to the State of California to cause cancer, birth defects or other Reproductive harm.

(California Health & Safety Code Section 25249.6- Proposition 65)



NOTE

The red goggles are intended to enhance the visibility of the laser beam. They will not protect your eyes against laser radiation.

- Do not remove or deface warning labels on the laser level.
- Do not disassemble the laser level, laser radiation can cause serious eye injury.
- Do not drop the laser.
- Do not use solvents to clean the laser.
- Do not use in temperatures below -10°C or above 45°C (14°F / 113°F)
- Do not operate the laser in explosive atmospheres such as flammable liquids, gases or dust. Sparks from the tool can cause ignition.
- When not in use, turn off the power, engage the pendulum lock and place the laser in the carrying pouch.
- Make sure the pendulum lock mechanism is engaged before transporting the laser.

NOTE

If the Pendulum lock mechanism is not engaged before transportation, internal mechanical damage can occur.

BATTERY INSTALLATION

1. Press down on the latch and remove the battery cover.
2. Insert 3 new AA batteries of the same brand according to the polarity diagram on the inside of the battery compartment.
3. Reclose the battery cover.

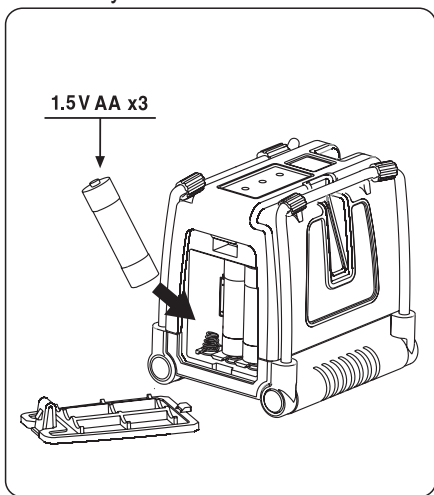

NOTE

If the laser level will not be used for a long period, remove the batteries from the battery compartment. This will prevent batteries from leaking and corrosion damage.

 **WARNING:** Batteries can deteriorate, leak or explode, and can cause injury or fire.

1. Do not shorten the battery terminals.
2. Do not charge Alkaline batteries.
3. Do not mix old and new batteries.
4. Do not dispose of batteries into household waste.
5. Do not dispose of batteries in fire.
6. Defective or dead batteries must be disposed according to local regulations.
7. Keep the batteries out of reach from children.

OVERVIEW

1. On/Off Locking Switch

2. Metal legs

3. Stabilizing rubber sleeve

4. Keypad

a. Manual Mode button

b. Beam Selector button

c. Pulse Mode button

d. Manual Mode LED

e. Laser Beam LED

f. Pulse Mode LED

5. Horizontal window

6. Forward vertical window

7. Side vertical window

8. Battery cover

9. ¼" tripod mount

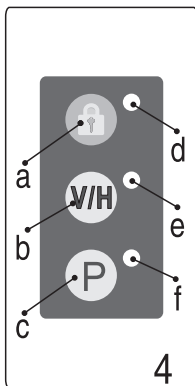
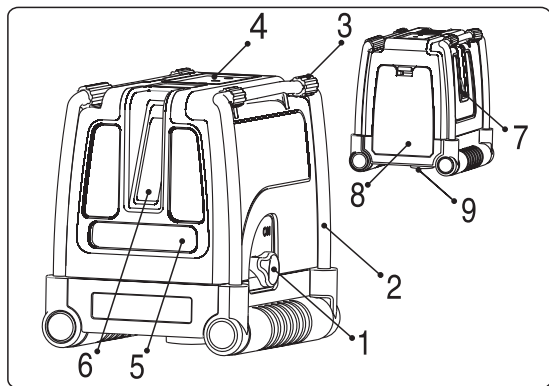

Working in Automatic mode (self-leveling):

In automatic mode the laser level will level itself in the range of $\pm 3^\circ$ and will project horizontally or vertically or all 3 beams simultaneously.

1. Remove the laser from the case and place it on a solid flat Vibration free surface or on a tripod.
2. Turn the locking switch #1 clockwise to the **ON** position.
The laser level will generate horizontal and vertical beams forward, and additional orthogonal side vertical beam. The green LED near the **V/H** push button will light up.
3. The laser will generate cross beams forward and cross beams upward above the laser when all beams are activated.
4. Choose the beams that you want to work with by pushing the Beam push button **V/H**
5. Use the adjustable metal legs #2 to adjust the height of the horizontal beam.
6. If the initial level of the laser is beyond $\pm 3^\circ$ and the automatic mode is activated the laser beams will flash and a beeping alarm will be heard. In this case reposition the laser on a more level surface.
7. Before moving the laser level switch the locking switch #1 to the **OFF** position this will lock the pendulum and protect your laser.

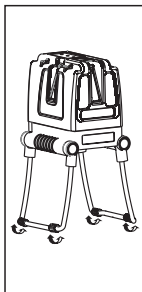
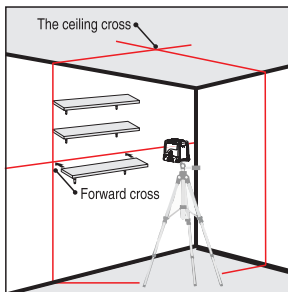

Working in Manual mode:

In Manual mode the 873's self-leveling mechanism is disabled and the laser lines can be set at any slope required. The laser beams will flash every 3 seconds to let you know that you are working outside the self-leveling range and the beams may not be leveled

1. Press the Manual push button mode . The laser will project the cross lines and the red LED near the push button will light up. The green LED of the laser beams near **V/H** push button will light up.
2. Choose the beams that you want to work with by pushing the Beam Selector push button **V/H**
3. To mark a slope, tilt the laser using the adjustable folding legs to adjust the right angle and the height.
4. To turn the manual mode off, press again the Manual push button .
5. While in Manual mode turning the locking switch #1 from **OFF** to **ON** will turn off the Manual mode and the red LED near the push button. The automatic self – leveling will be activated if the laser level is within the self – leveling range.

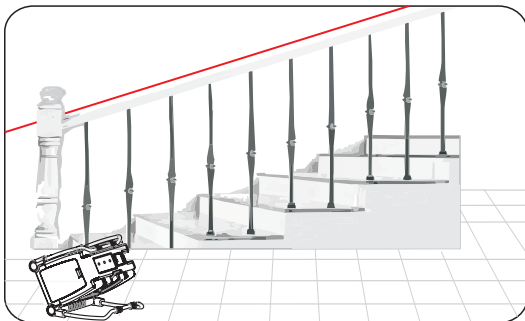

Working in Pulse mode with a detector:

For outdoor work under direct sunlight, or bright conditions and for extended indoor ranges up to 50 meters, use the pulse mode with a Detector.

When the pulse mode is activated the laser beams will flash at a very high frequency (Invisible to the human eye) this will allow the detector to detect the laser beams.

1. The pulse mode can be activated in Automatic and Manual modes.
2. To switch on the Pulse Mode press the **P** button, the green LED near the **P** push button will light up.
3. When the pulse mode is switched on, the visibility of the laser beams are reduced a little bit.
4. To switch off the Pulse Mode press the **P** button again, the green LED near the **P** push button will go off.

MAINTENANCE

To maintain the accuracy of your project, check the accuracy of your laser level according to the field calibration tests procedures.

- Change the batteries when the laser beams begin to dim.
- Wipe the aperture lens and the body of the laser level with a clean soft cloth. Do not use solvents.
- Although the laser level is dust and dirt resistant to a certain degree do not store in dusty places as a long term exposure may damage internal moving parts.
- If the laser level is exposed to water, dry the laser level before returning it to the carrying case to prevent corrosion damages.
- Remove the batteries if the laser level is unused for a long period of time to prevent corrosion damages.

This laser level left the factory fully calibrated. Kapro recommend that the user will check the accuracy of the laser periodically, or if the unit falls or is mishandled.

1. Check the height accuracy of the horizontal beam.
2. Check the leveling accuracy of the horizontal beam.
3. Check the leveling accuracy of the vertical beam.
4. Check the perpendicularity between the 2 vertical beams.

1. Checking the Height Accuracy of the Horizontal beam. (Up and down deviation)

- 1) Set up the laser on a tripod or on a solid surface between two walls **A** and **B**, approximately 5 meters apart.
- 2) Position the laser level approximately 0.5 meter from wall **A**
- 3) Unlock the pendulum and press the button to project the horizontal and the vertical cross beams towards wall **A**.
- 4) Mark on the wall the center of the cross beams as **a1** (see figure # 1).

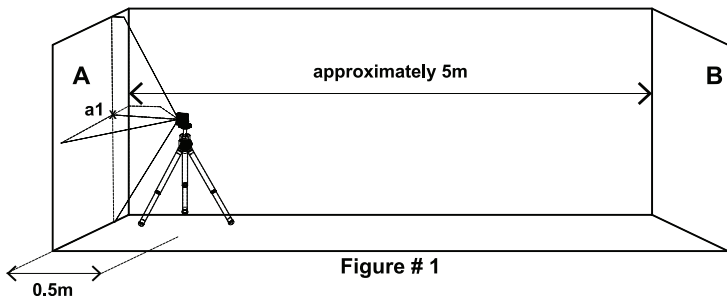

Figure # 1

- 5) Turn the laser 180° towards wall **B**, and mark on the wall the center of the cross beams as **b1** (see figure 2).

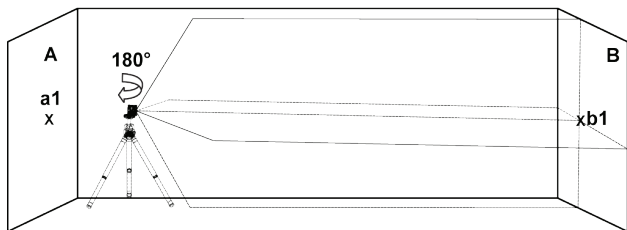

Figure # 2

- 6) Move the laser level towards wall **B** and position it approximately 0.5 meter from wall **B**.
- 7) Mark on wall **B** the center of the cross beams as **b2** (see figure 3).

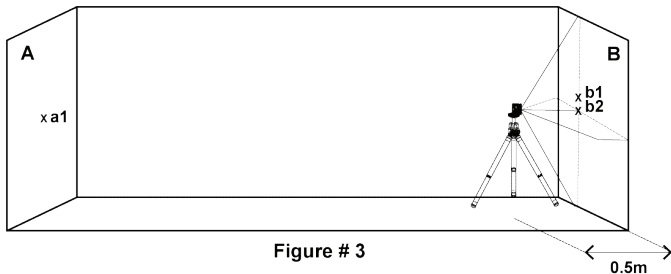

Figure # 3

- 8) Turn the laser 180° towards wall **A**, and mark on the wall the center of the cross beams as **a2** (see figure 4).

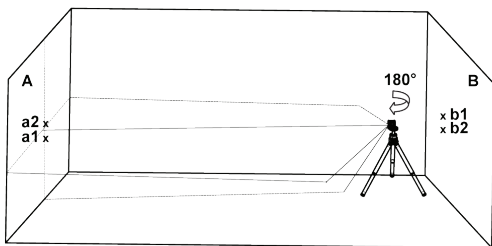

Figure # 4

- 9) Measure the distances:

$$\Delta a = |a2 - a1|$$

$$\Delta b = |b1 - b2|$$

- 10) The difference $|\Delta a - \Delta b|$ should not be more than 2 mm, otherwise to send the laser level to a qualified technician for repairs.

2. Checking the Level Accuracy of Horizontal beam. (Side to side inclination)

- 1) Set up the laser on a tripod or on a solid surface at a distance of approximately 1.5 meters from a wall 5 meters long.
- 2) Unlock the pendulum and press the button to project the horizontal and the vertical cross beams towards the wall.

- 3) Mark point **a1** on the wall, in the middle of the horizontal line at the left edge of the horizontal beam (see figure 5).

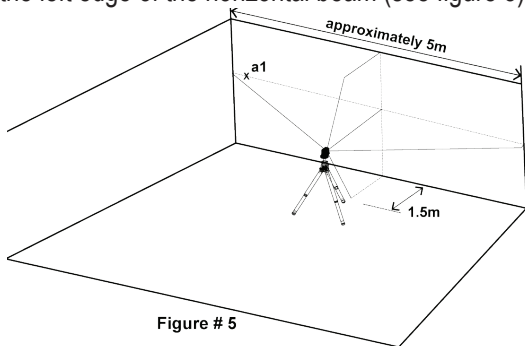

Figure # 5

- 4) Turn the laser level counterclockwise until the right edge of the horizontal beam reach's near **a1**, mark a point **a2** on the wall in the middle of the horizontal beam (see figure 6).

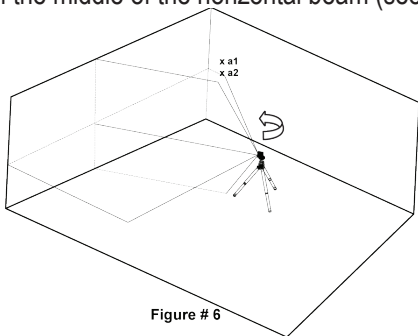
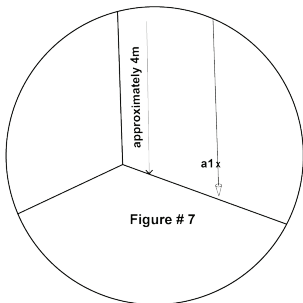

Figure # 6

- 5) The distance between a1 and a2, should not be more than 1 mm, otherwise to send the laser level to a qualified technician for repairs.

3. Checking the Accuracy of the Vertical beam.

- 1) Hang approximately 4 meter plumb line on a wall.
- 2) After the plumb line has settled, Mark point **a1** on the wall behind the plumb line near the plumb cone. (see figure 7).



- 3) Set up the laser on a tripod or on a solid surface in front of the wall at a distance of approximately 2 meters.
- 4) Unlock the pendulum, and press the button to project the vertical beam towards the plumb line.
- 5) Turn the laser so that the vertical beam will merge with the plumb line below the hanging point.

- 6) Mark point **a2** on the wall, in the middle of the vertical beam at the same height of **a1**. (see figure 8).

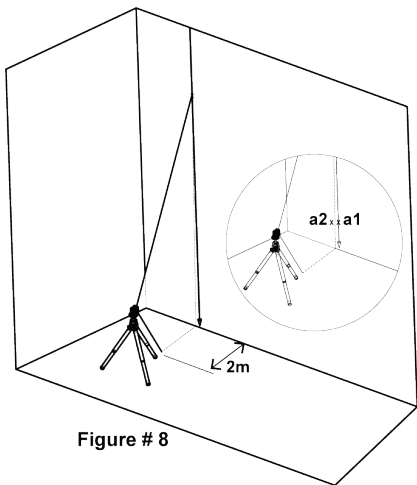

Figure # 8

- 7) The distance between **a1** and **a2**, should not be more than 1mm, otherwise to send the laser level to a qualified technician for repairs.

4. Checking 90° accuracy between the 2 vertical beams.

This procedure requires a room of at least 5x5 meters with 4 walls.

- 1) Set up the laser on a table or on the floor in the middle of the room.
- 2) Unlock the pendulum, and press the **V/H** push button 4 times to project the forward and the side vertical beams (see figure 9).

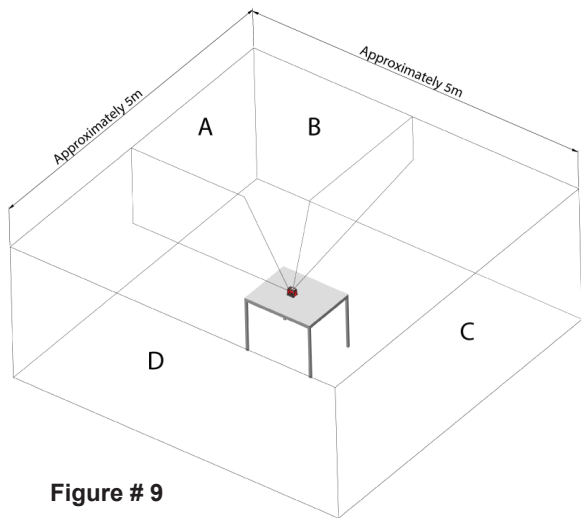
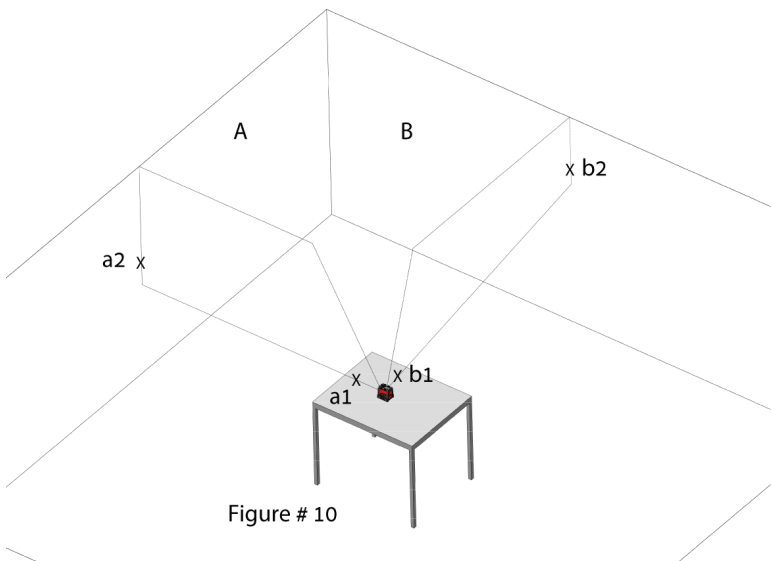
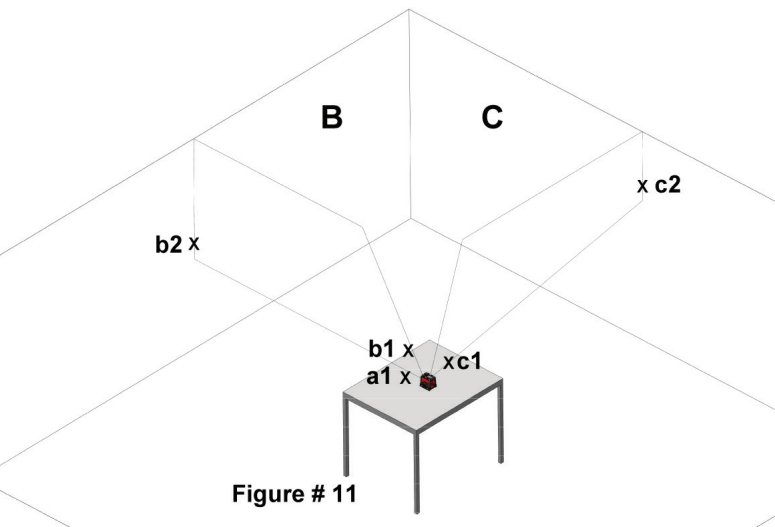

Figure # 9

- 3) Mark the center of the forward vertical beam at 2 locations.
point **a1** on the table near the laser, and point **a2** on the wall **A**.
- 4) Mark the center of the side vertical beam at 2 locations.
point **b1** on the table near the laser, and point **b2** on the wall **B**.
(see figure 10).



- 5) Rotate the laser clockwise so that the forward laser beam passes through marks **b1** on the table, and **b2** on the wall **B**.
- 6) Mark the center of the side vertical beam at 2 locations. Point **c1** on the table near the laser, and point **c2** on the wall **C**. (see figure 11).



- 7) Rotate the laser clockwise so that the forward laser beam passes through marks **c1** on the table, and **c2** on the wall **C**.
 - 8) Mark the center of the side vertical beam at 2 locations. Point **d1** on the table near the laser, and point **d2** on the wall **D**.
- (see figure 12).

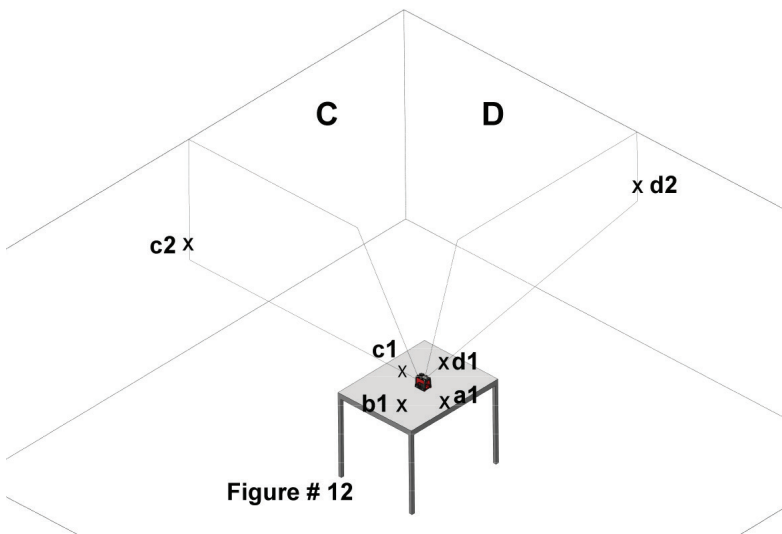

- 9) Rotate the laser clockwise so that the forward laser beam passes through marks **d1** on the table, and **d2** on the wall **D**.
- 10) Mark the center of the side vertical beam at 2 locations. Point **a3** on the table near the point **a1**, and point **a4** on the wall **A** near the point **a2**. (see figure 13).

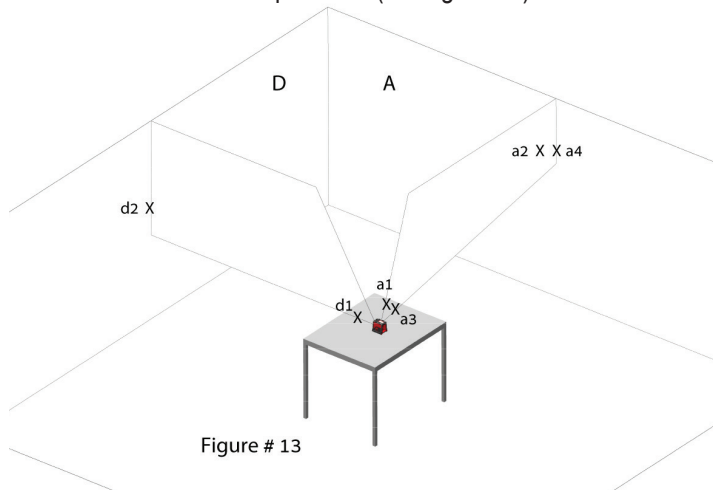

Figure # 13

- 11) Measure the distances:

$\Delta 1 =$ from **a1** to **a3**

$\Delta 2 =$ from **a2** to **a4**

- 12) The difference $\Delta 2 - \Delta 1$ should not be more than 3 mm, otherwise to send the laser level to a qualified technician for repairs.

SPECIFICATIONS

Laser beams output pattern	Horizontal and 2 orthogonal vertical beams Horizontal and forward vertical cross beams Horizontal beam Forward vertical beam Forward and side orthogonal verticals
Laser range	<ul style="list-style-type: none">• Indoor - 100ft (30m)• Outdoor with detector 165ft (50m)
Accuracy	$\pm 0.2\text{mm/m}$ ($\pm 0.0002\text{in/in}$)
Fan angle	$120^\circ \pm 5^\circ$
Self-leveling Range	$\pm 3^\circ$
Laser line width	2mm $\pm 0.5\text{mm}/5\text{m}$ (0.10" ± 0.02 " at 20')
Wavelength	635 $\pm 5\text{nm}$ Laser Class II
Power supply	3 AA batteries (included)
Battery life	15 hours of continuous operation
Operating temp	-10° C +45° C (14°F - 113°F)
Storage temp	-20° C +60° C (-4°F - 140°F)
Water & dust proof	IP54
Dimensions	10.6cm x 8.8cm x 10.5cm (4.1" x 3.4" x 4.0")
Weight including batteries	710gr \pm 10gr (1.56lbs \pm 0.3oz)



WARRANTY

This product is covered by a two-year limited warranty against defects in materials and workmanship. The warranty does not cover products that are used improperly, altered or repaired without Kapro Tool's approval. In the event of a problem with the laser level, please return the product to the place of purchase with proof of purchase.

Model #873 Prolaser® Vector

The serial number sticker is positioned inside the battery compartment.

CE CONFORMITY CERTIFICATE

This product meets the standards of the Electromagnetic Compatibility (EMC) established by the European Directive 2014/30/EU and the Low Voltage Directive (LVD) 2014/35/EU

EC DECLARATION OF CONFORMITY

We declare under our responsibility that the product 873 is in accordance with the requirements of the Community Directives and Regulations:

2014/30/EU

2011/65/EU

EN60825-1: 2014

EN61326-1: 2013

